

README // about these slides

These are the slides for the talk presented at CHI 2026 by Yudai Tanaka.

All the links in this PDF are clickable and lead you to YouTube videos, paper, etc.

You can watch the live talk [here: https://youtu.be/nQI-65DbsIA?si=y7G4ILrXUZf0upAp](https://youtu.be/nQI-65DbsIA?si=y7G4ILrXUZf0upAp)

You can watch the video [here: https://www.youtube.com/watch?v=M0EVjipRmPU](https://www.youtube.com/watch?v=M0EVjipRmPU)

If you need a PPTX/editable version for your class, email us hci@uchicago.edu

More on this paper (or others of our lab) at: <https://lab.plopes.org/#myoaction>

Myo Action: Accelerating Voluntary Actions via Electromyography and Muscle Stimulation

Yudai Tanaka, Che-Wei Hsu, Bruno Felalaga, Pedro Lopes. In Proc. CHI'26 (paper)

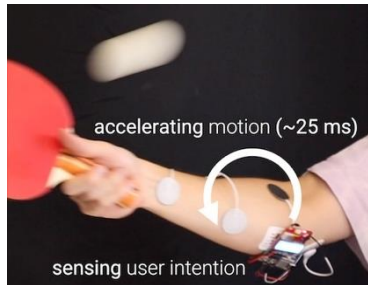

We propose a technique for accelerating users' action without overriding intention, thereby preserving agency. In our approach, it is the user's muscle signals, detected via electromyography (EMG), that trigger electrical-muscle-stimulation (EMS) without external sensors or stimulation-timing calibration. The key to enable this "agentic speedup" is a synergy between EMG and EMS: EMG can detect an early-onset of the neural-response; EMS can contract a muscle faster than a typical voluntary-contraction. This—coupled with our low-latency system (290 μ s)—results in an accelerated reaction time, even though the haptic-assistance is initiated after the muscle-signal. In our study, we confirmed that our novel approach: accelerated users' reaction-time; preserved agency in decision-involving actions (i.e., go/no-go trials); and participants felt it augmented their performance. This puts forward embodied-assistance that aligns with users' decisions/intentions.



[click for paper PDF](#)



[click for Paper Video](#)



[click for CHI Talk \(live\)](#)

myo action: accelerating *voluntary* actions via electromyography and muscle stimulation

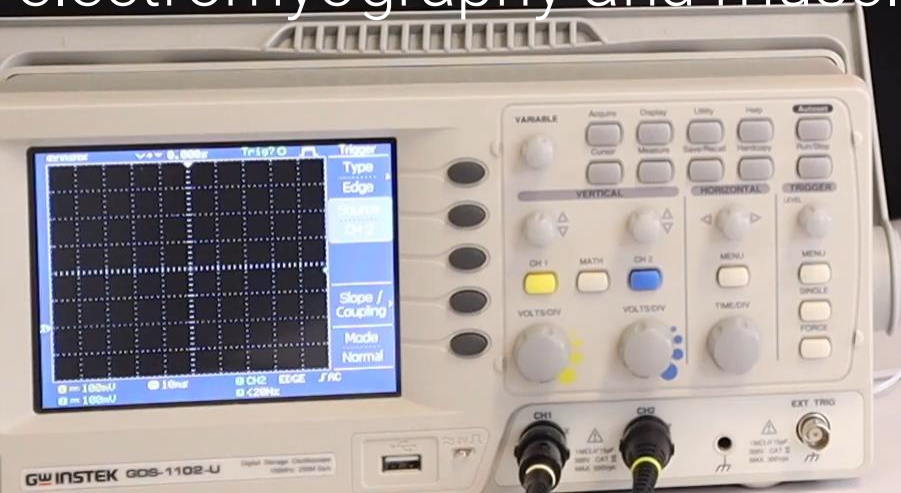

yudai tanaka, che-wei hsu,
bruno felalaga, pedro lopes

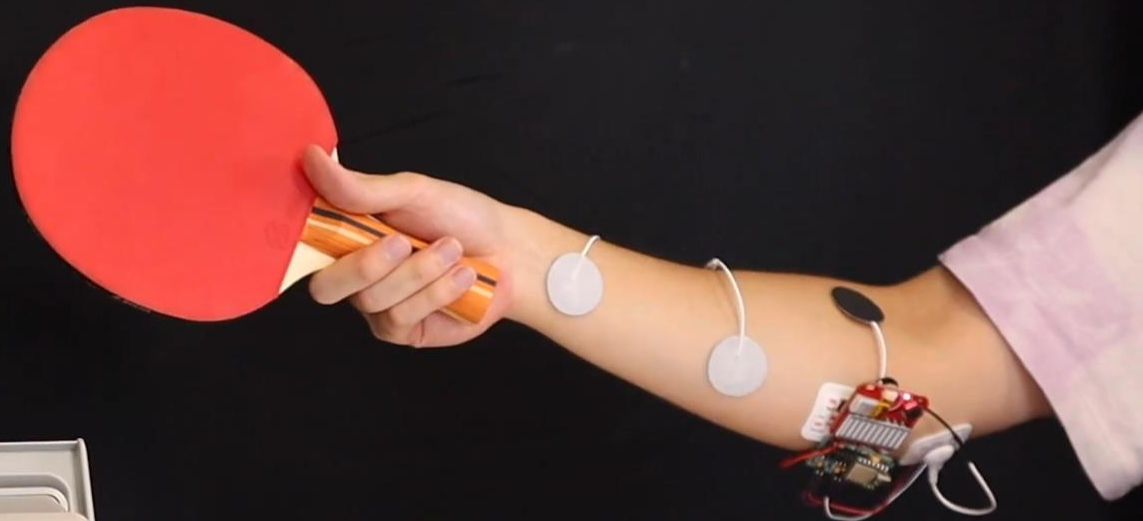
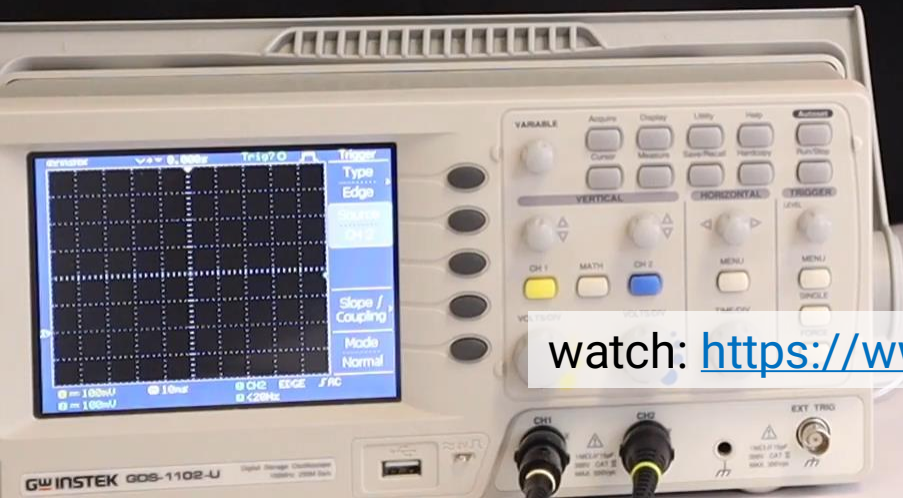

watch: <https://www.youtube.com/watch?v=M0EVjipRmPU>

what if the user decided not to hit?

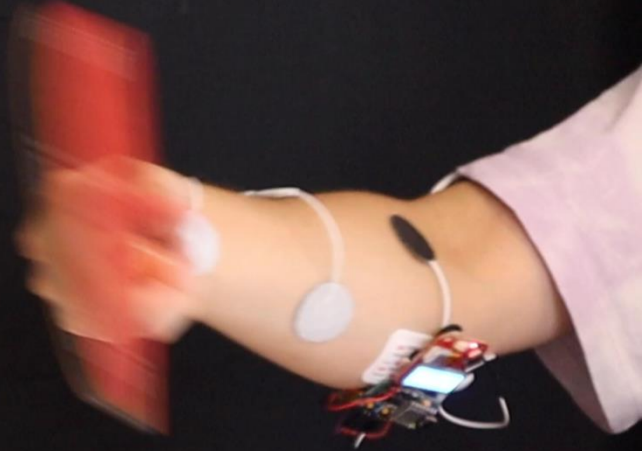
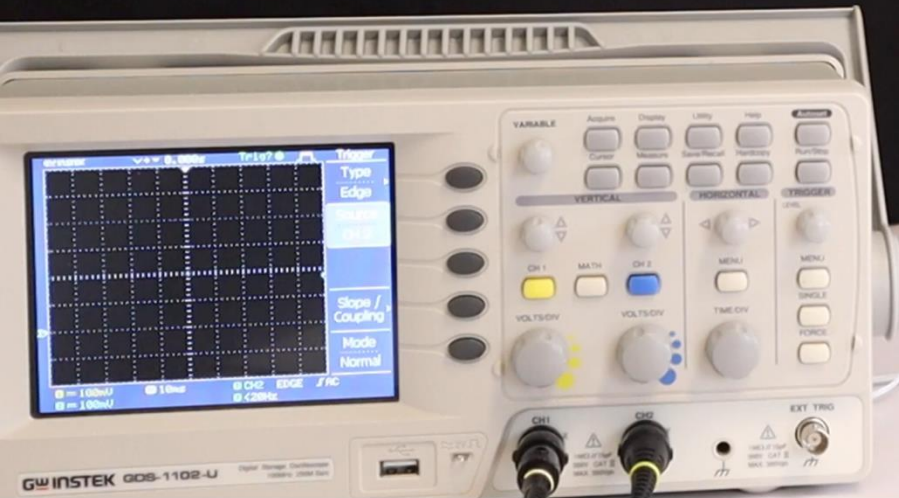

motivation:

augmentation overrides user intentions



fast decision (Nishida et al.)

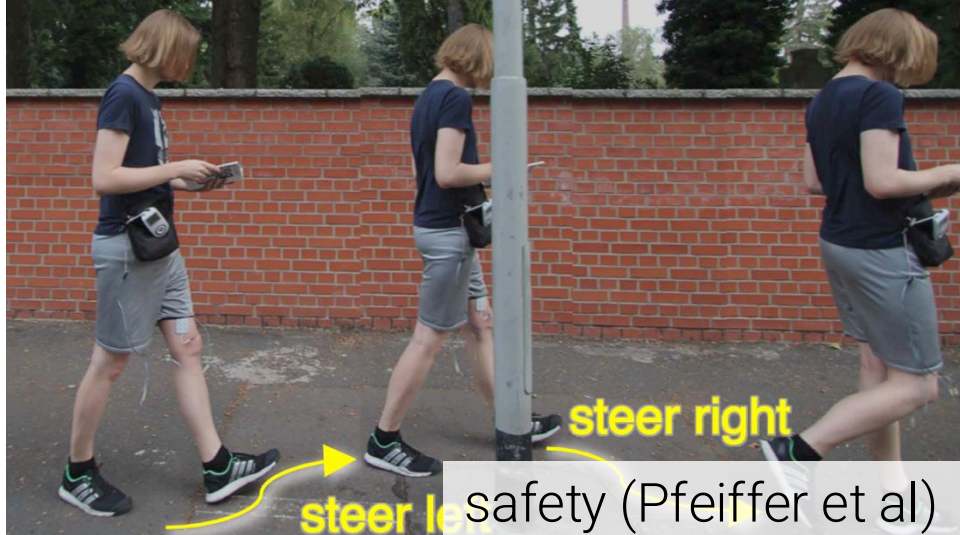

safety (Pfeiffer et al)

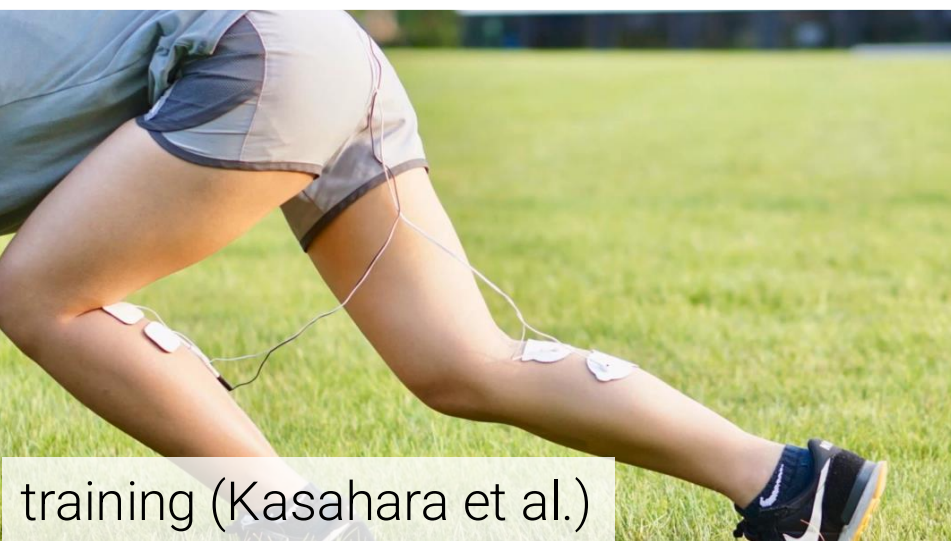

training (Kasahara et al.)



e-sports (Zhou et al.)



electrical muscle stimulation (**EMS**)

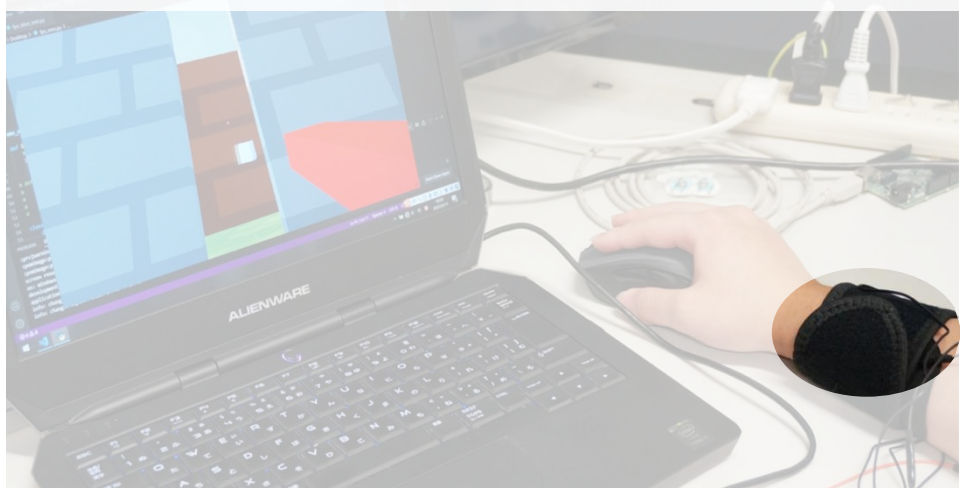



they force one outcome, overriding their intention



our approach:
closed-loop acceleration based on user intention

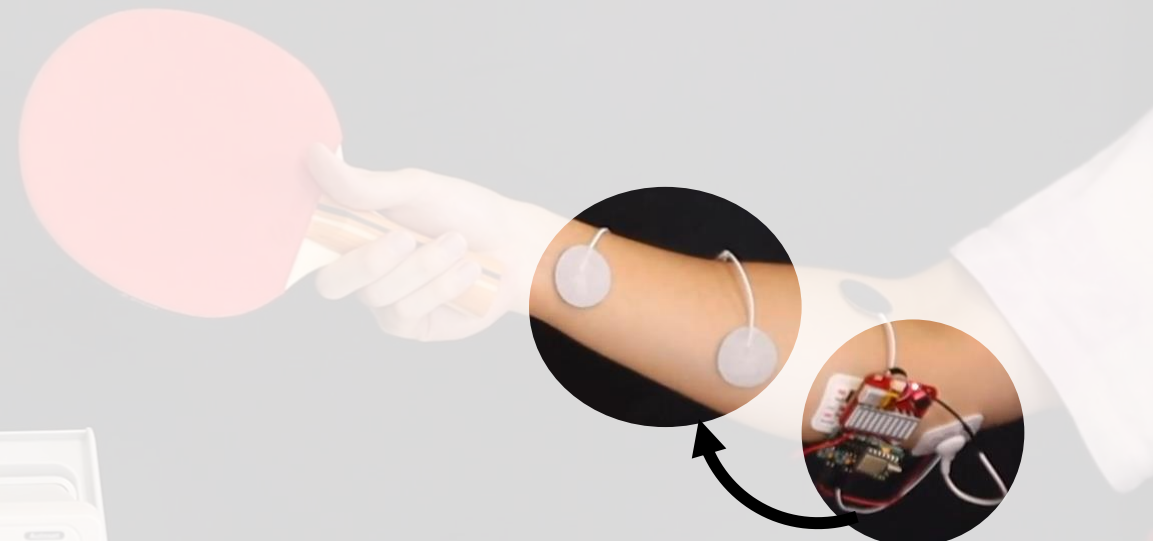
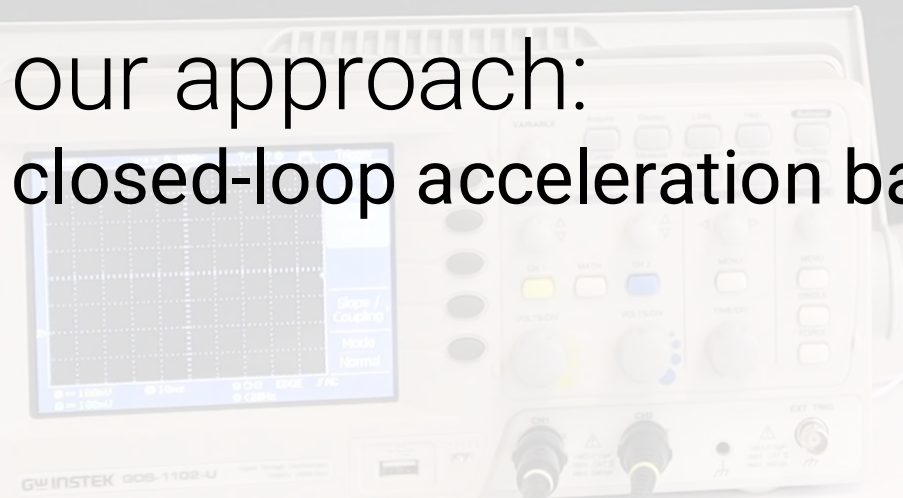

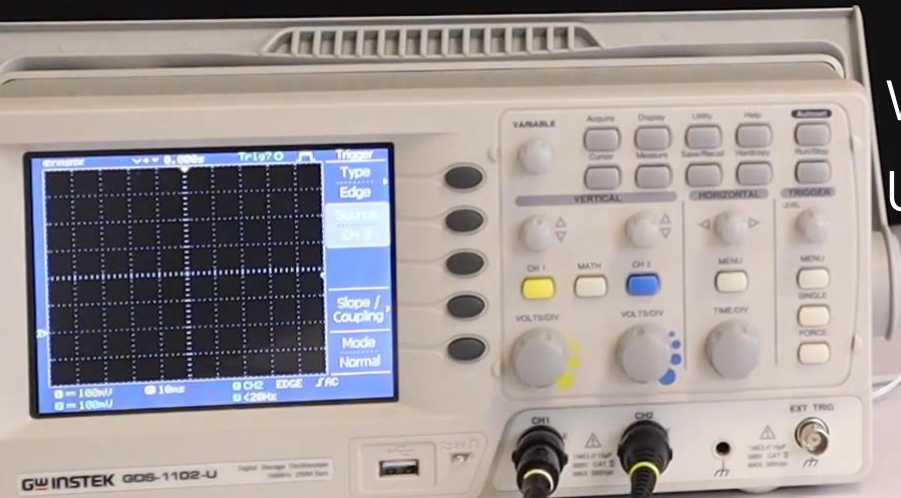

we sense user's intention
using electromyography (EMG)

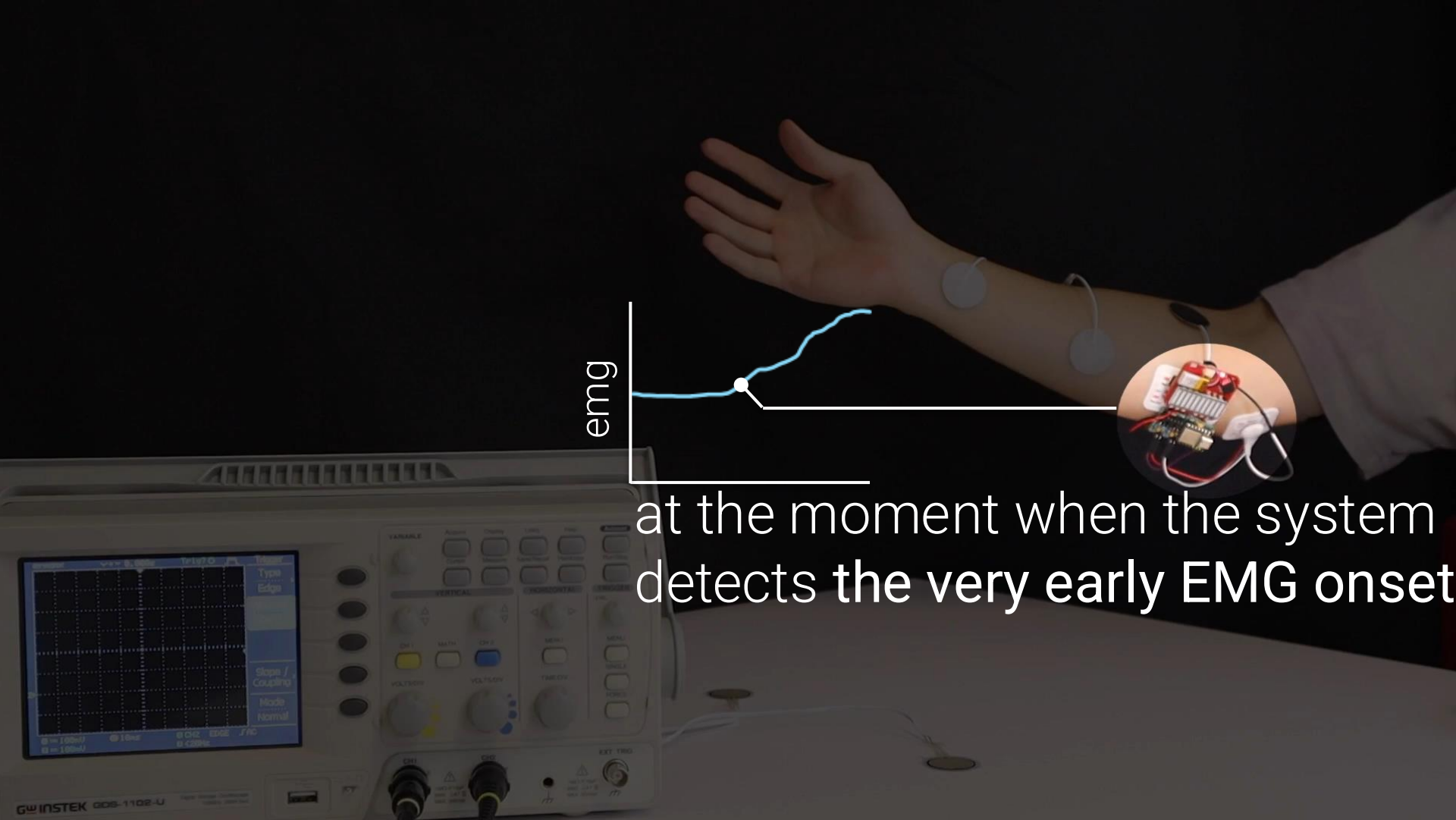

emg

at the moment when the system detects the very early EMG onset



we activate muscle stimulation (EMS)

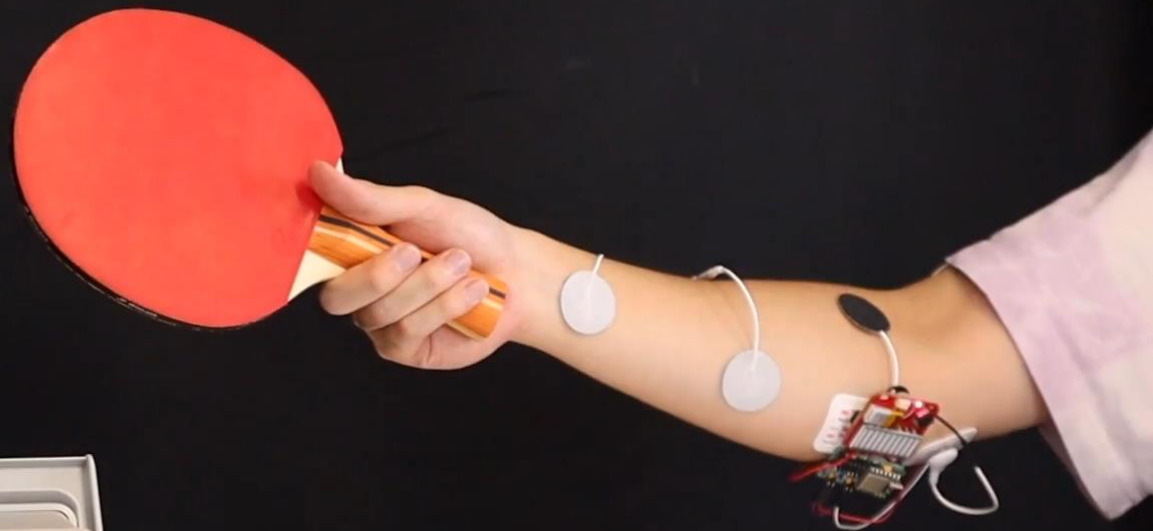
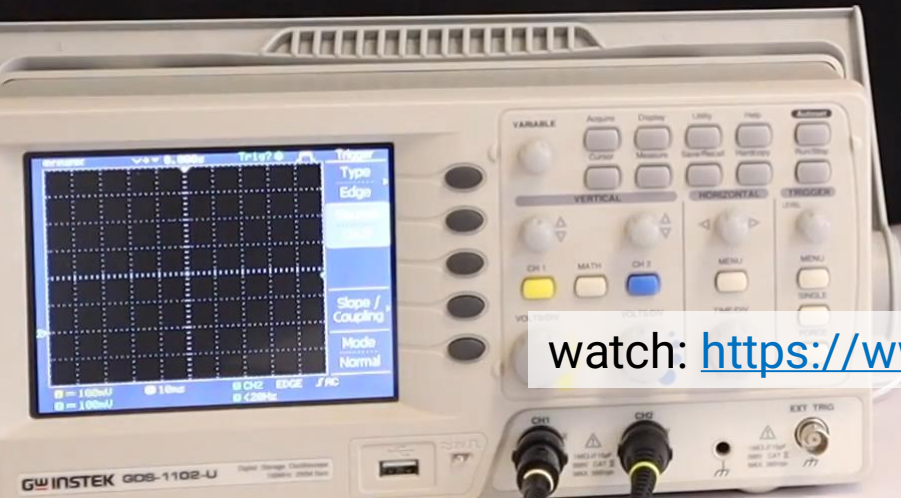

this is how our system
can adapt to user' intention

watch: <https://www.youtube.com/watch?v=M0EVjipRmPU>

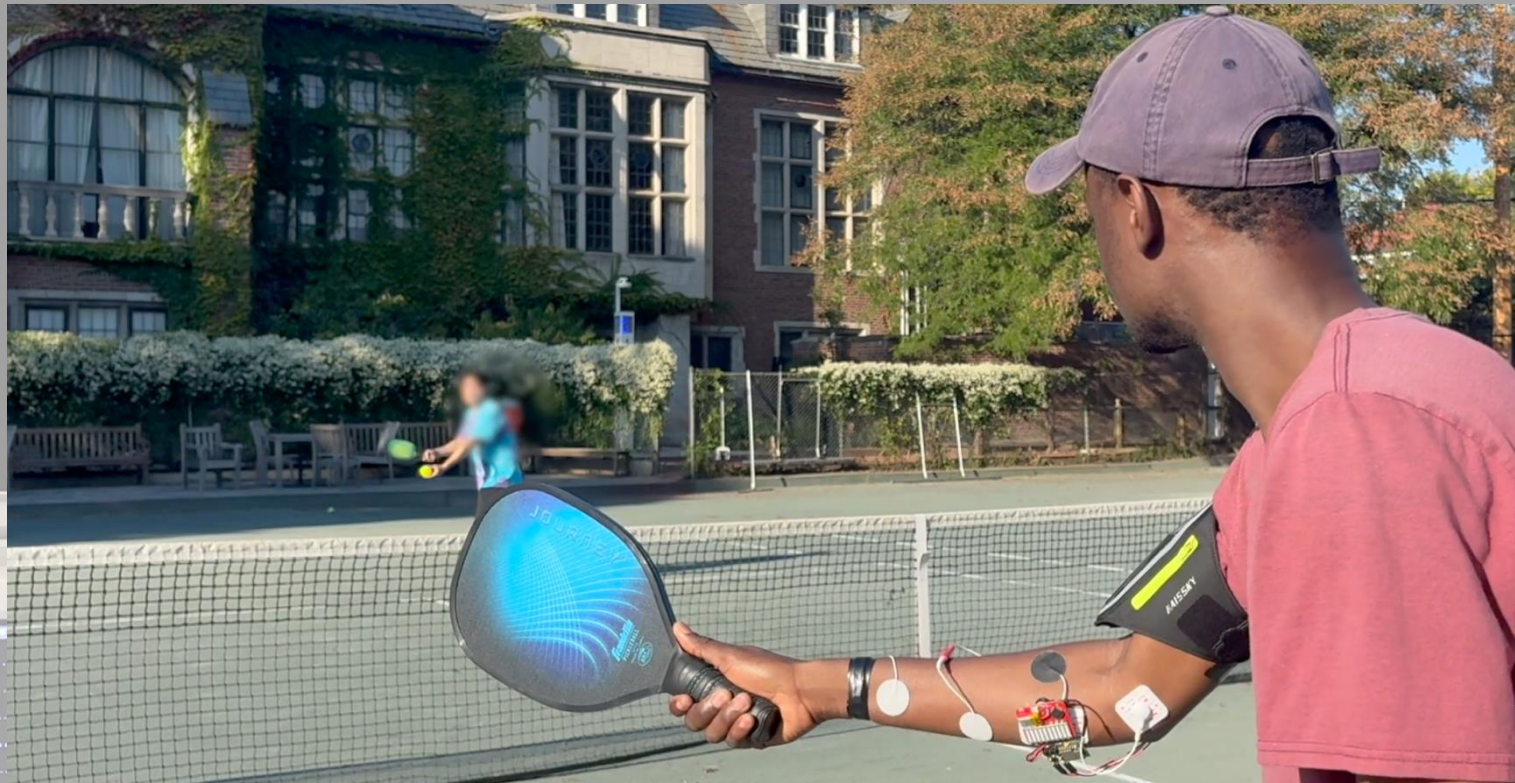

watch: <https://www.youtube.com/watch?v=M0EVjipRmPU>

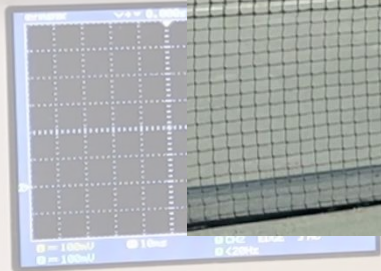

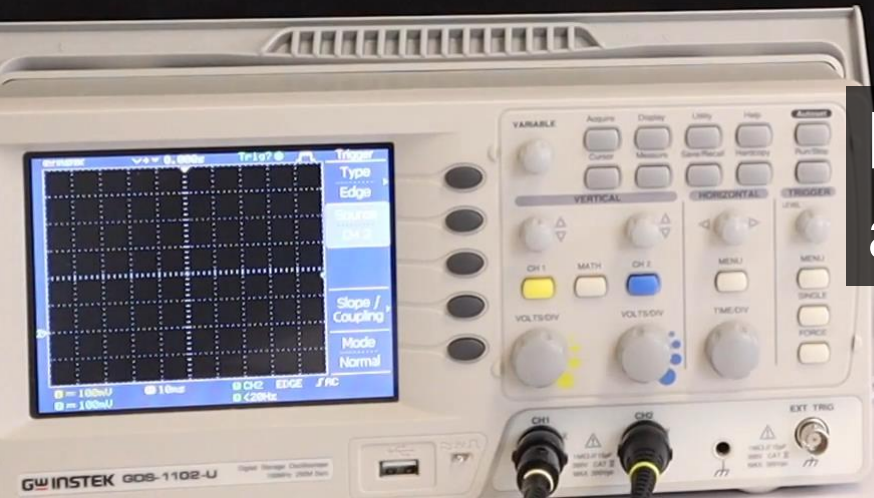

but if the system is triggered after the muscle signal is read

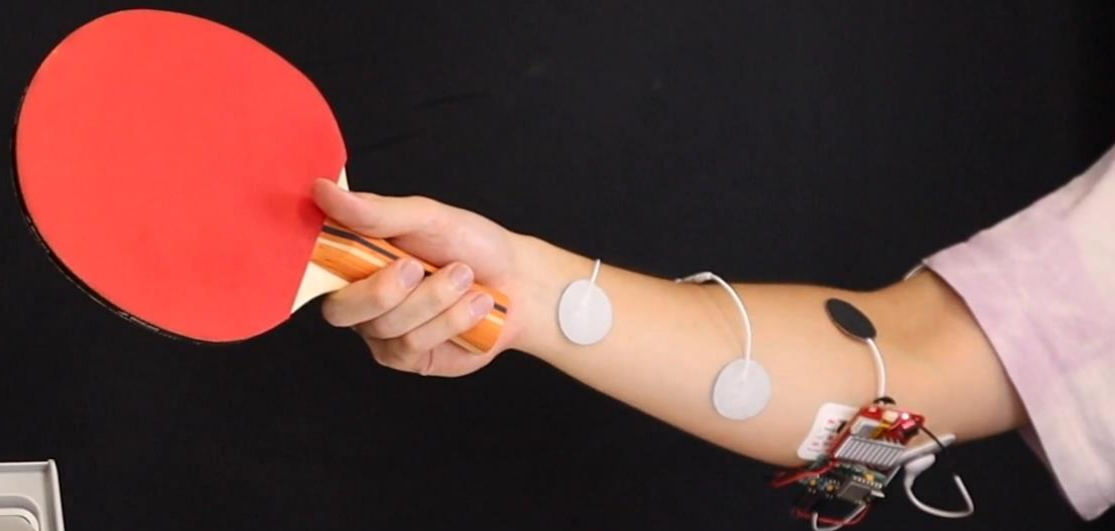
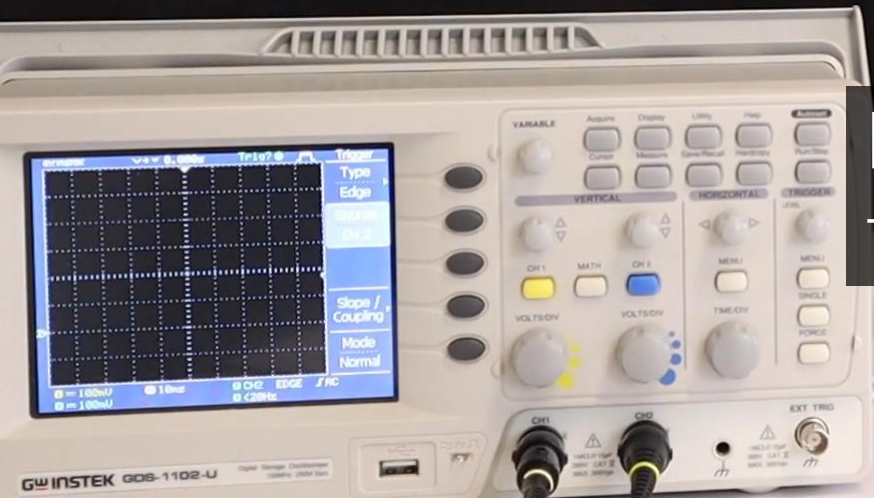

how is it possible to accelerate the movement?

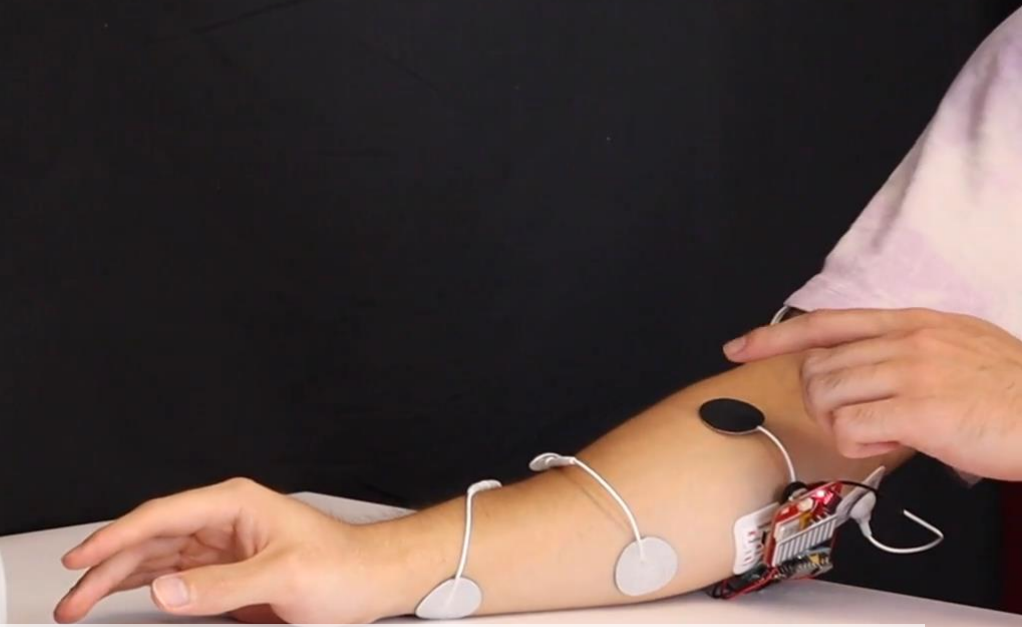
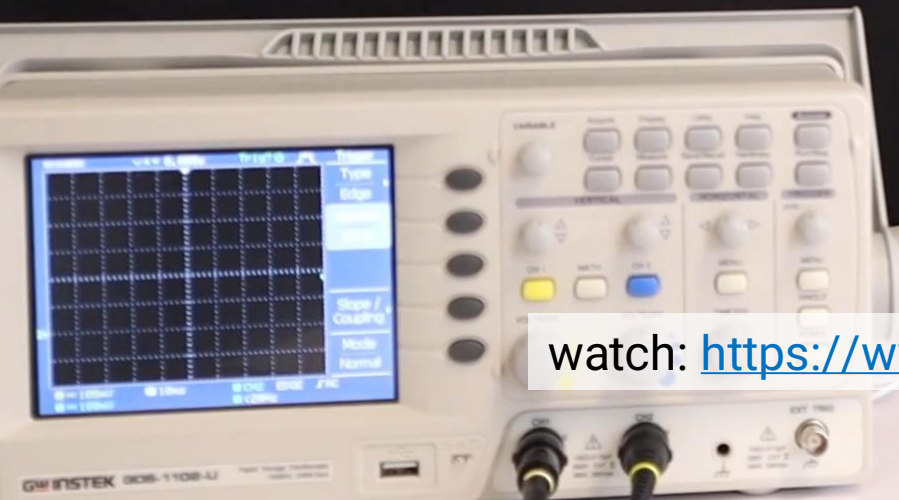

watch: <https://www.youtube.com/watch?v=M0EVjipRmPU>

stimulation can move your muscle **faster than you do**
(henneman's size principle)

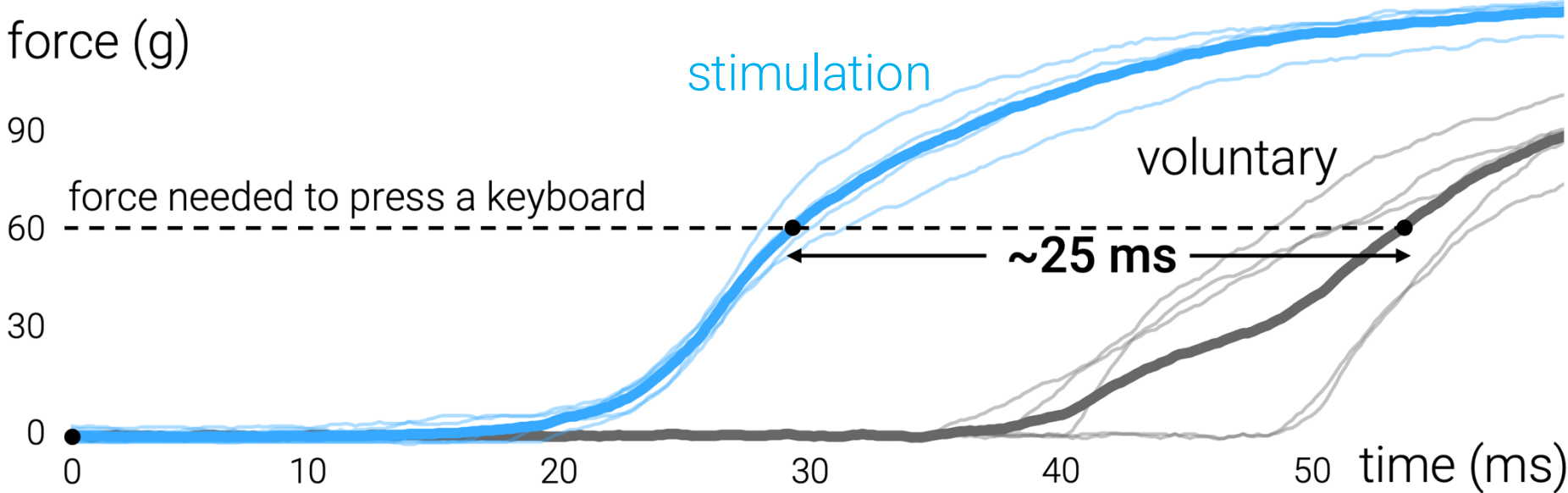

... but by only 25 ms; thus, system latency = crucial

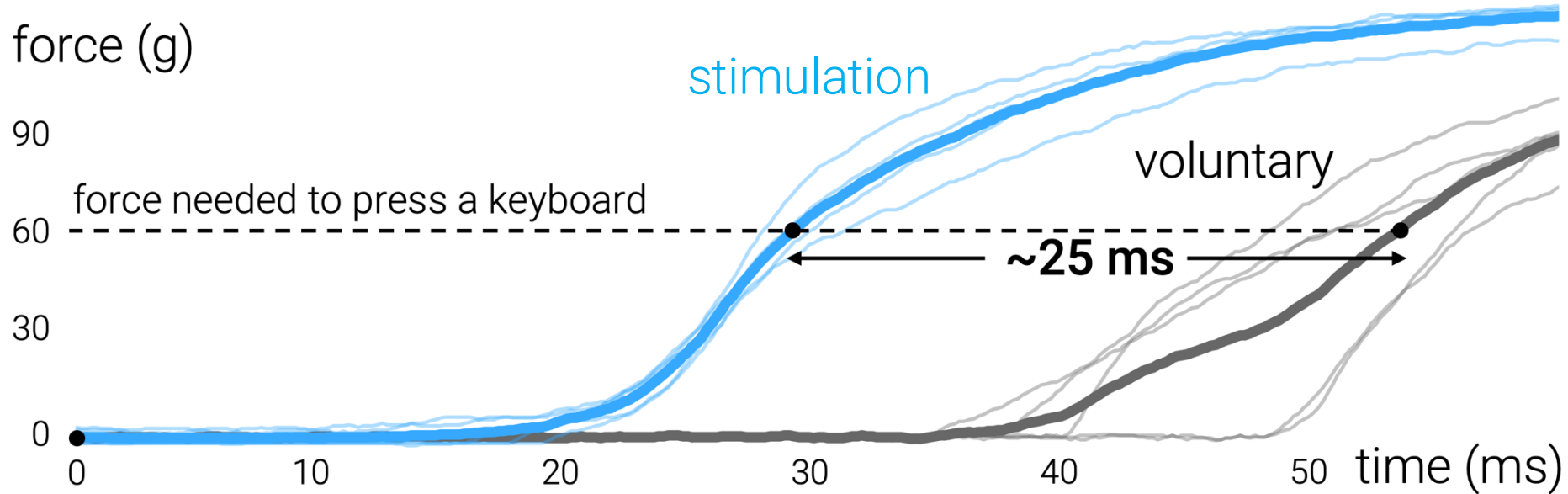

implementation:

microsecond-latency coupling of EMG and EMS

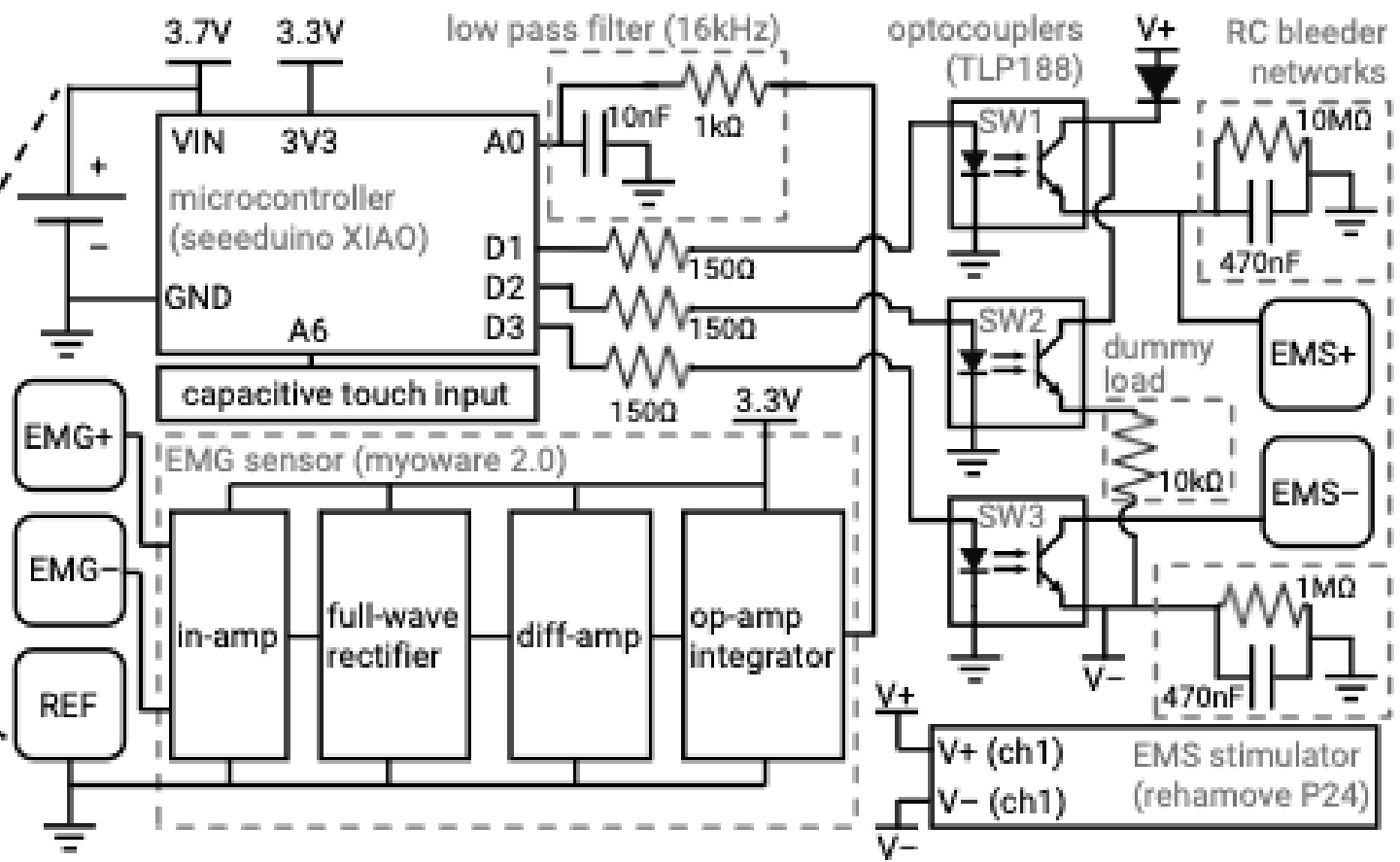
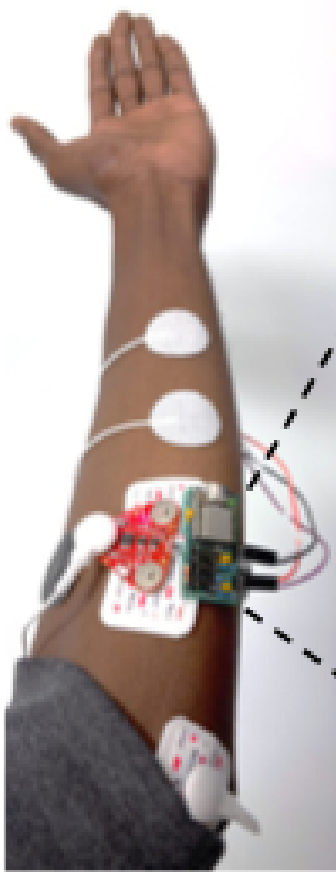

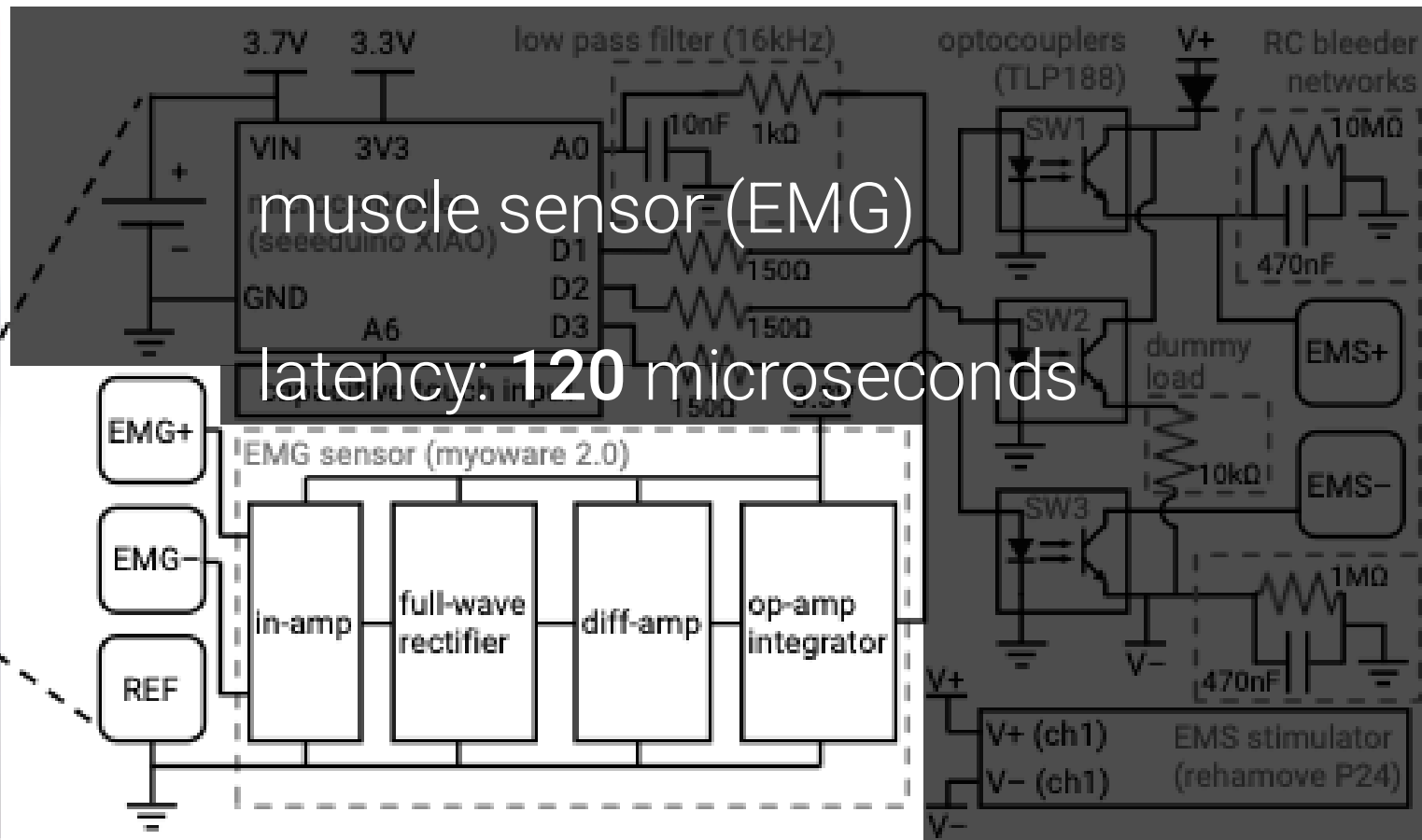
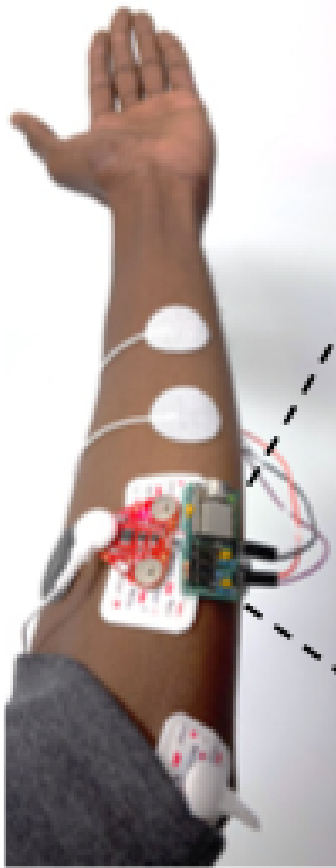

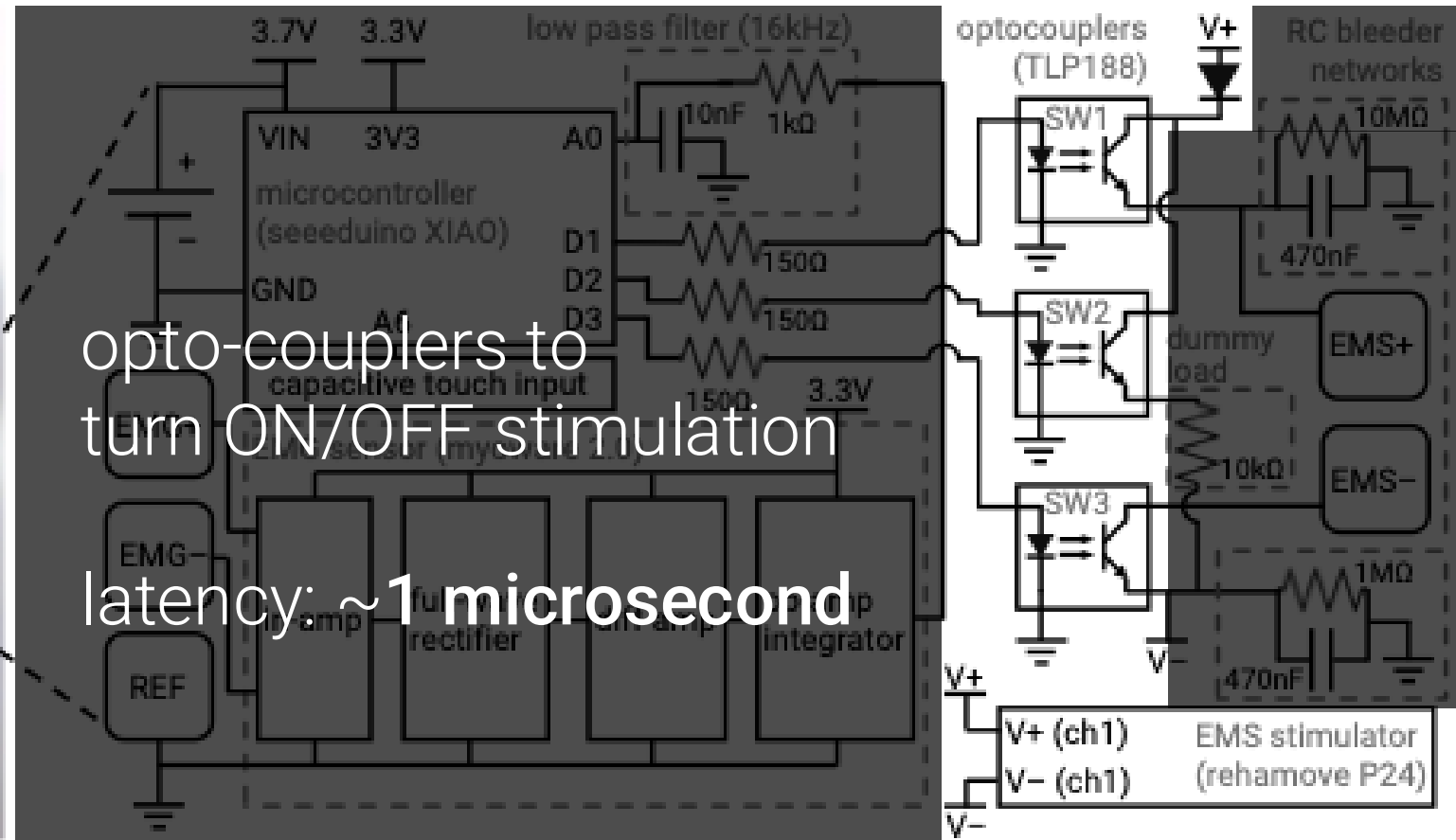
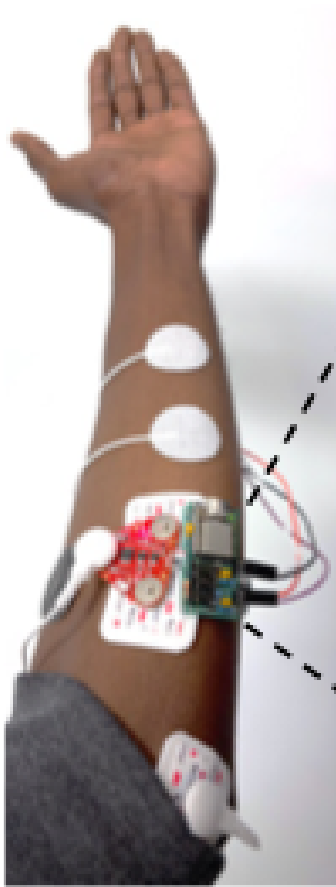

opto-couplers to turn ON/OFF stimulation

latency: ~1 microsecond

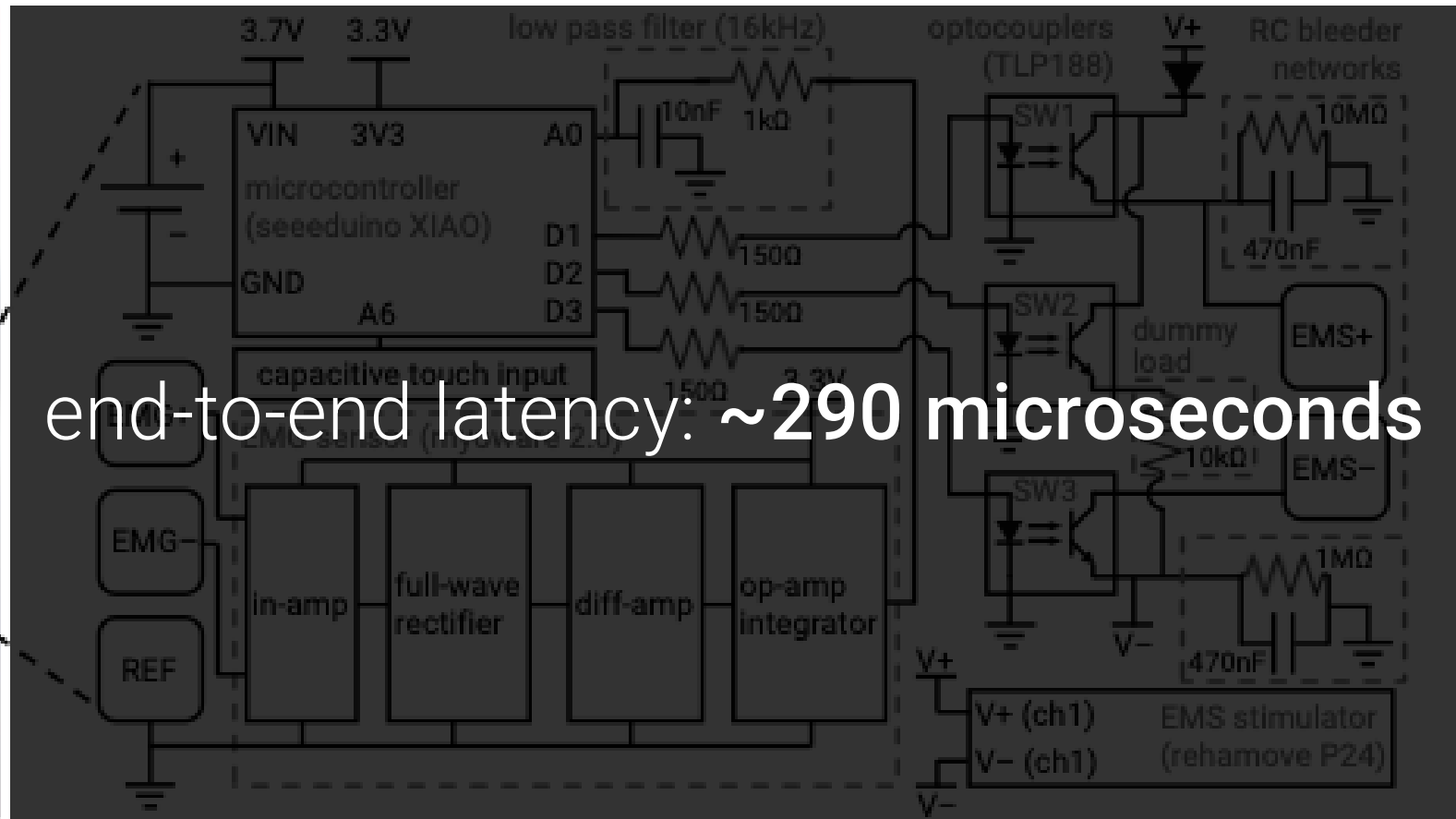
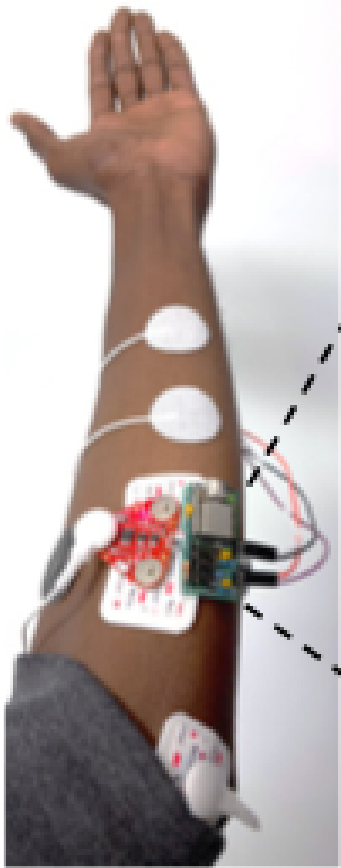

user study:

reaction time & agency in decision-based actions

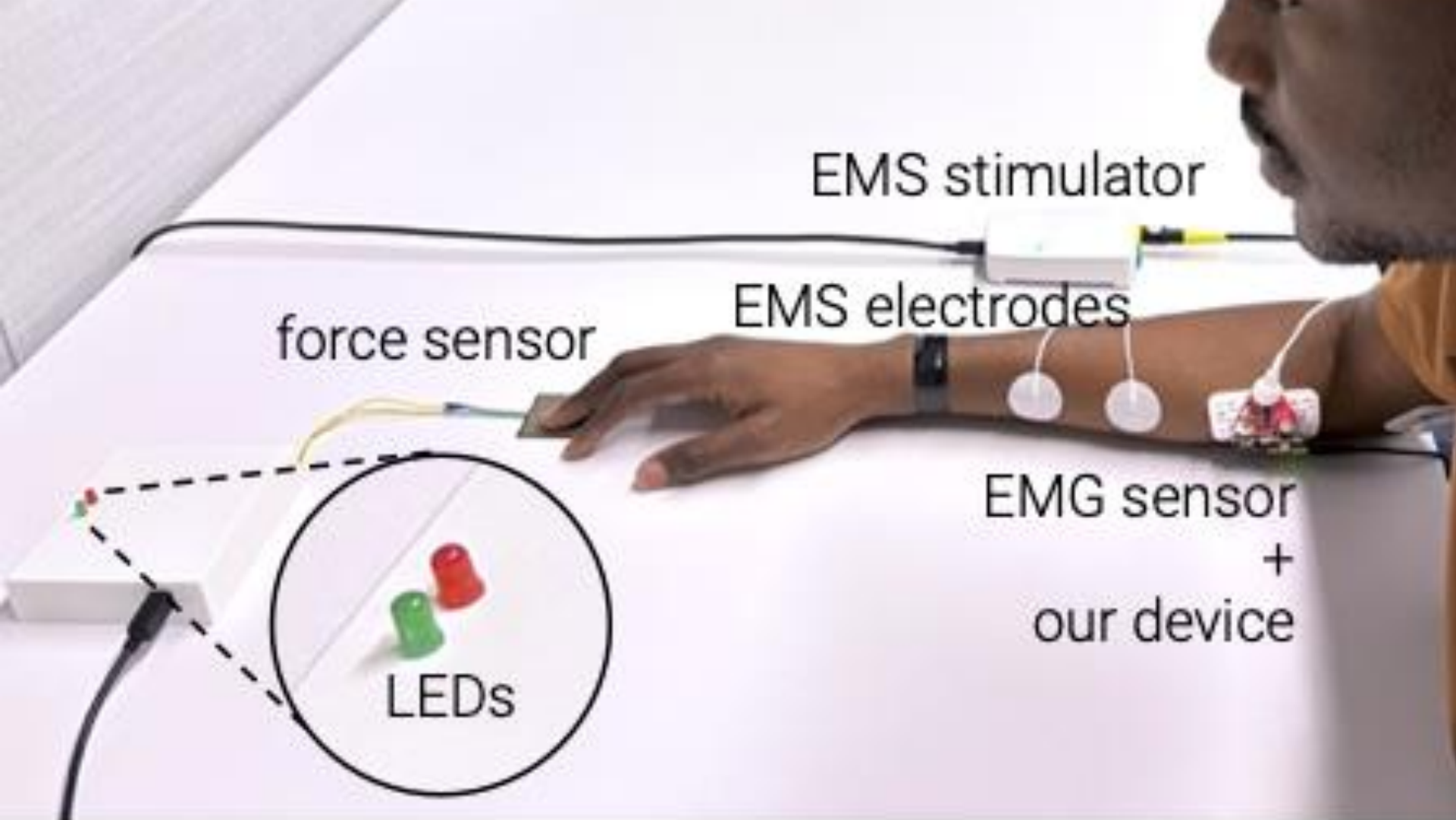

EMS stimulator

EMS electrodes

force sensor

EMG sensor
+
our device

LEDs

EMS stimulator

EMS electrodes

EMG sensor
+
our device

force sensor

LEDs

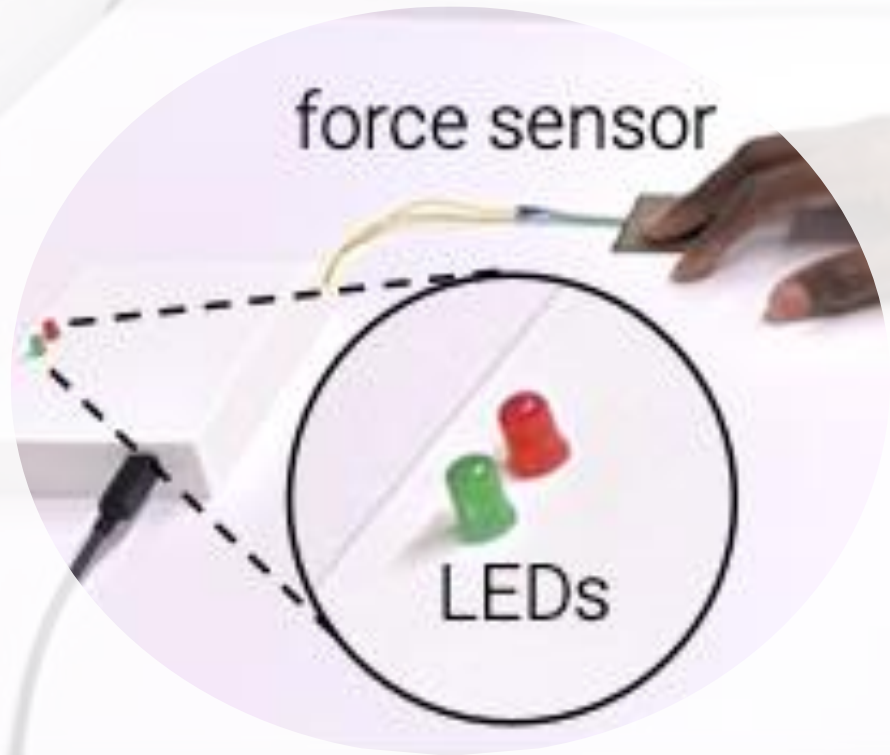

EMS stimulator

EMS electrodes

EMG sensor

+

our device

force sensor

LEDs

go: press the sensor

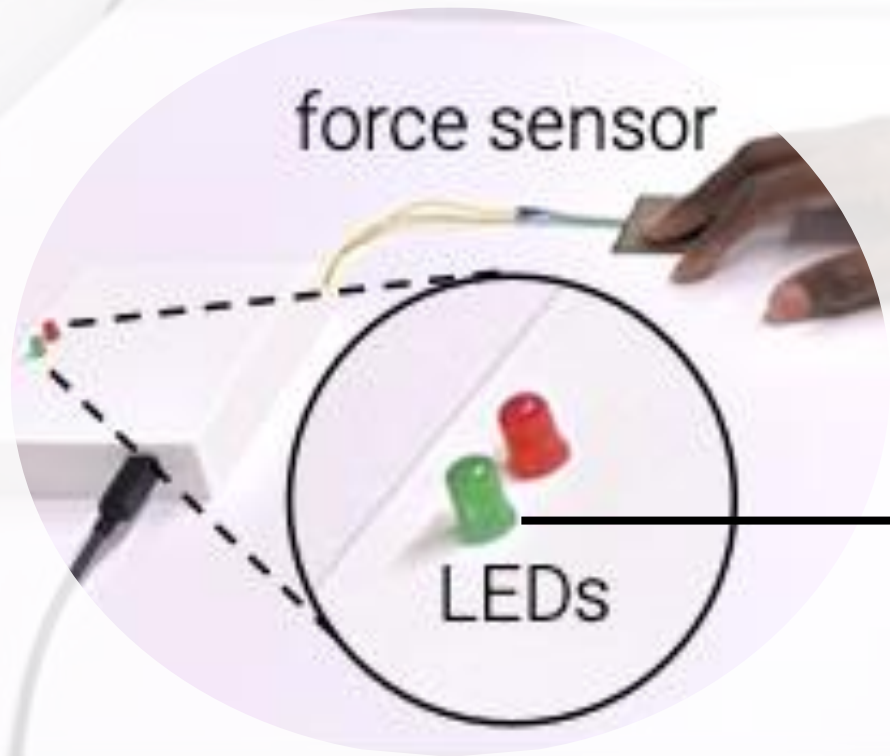

EMS stimulator

EMS electrodes

EMG sensor

force sensor

no-go: don't press the sensor
our device

LEDs

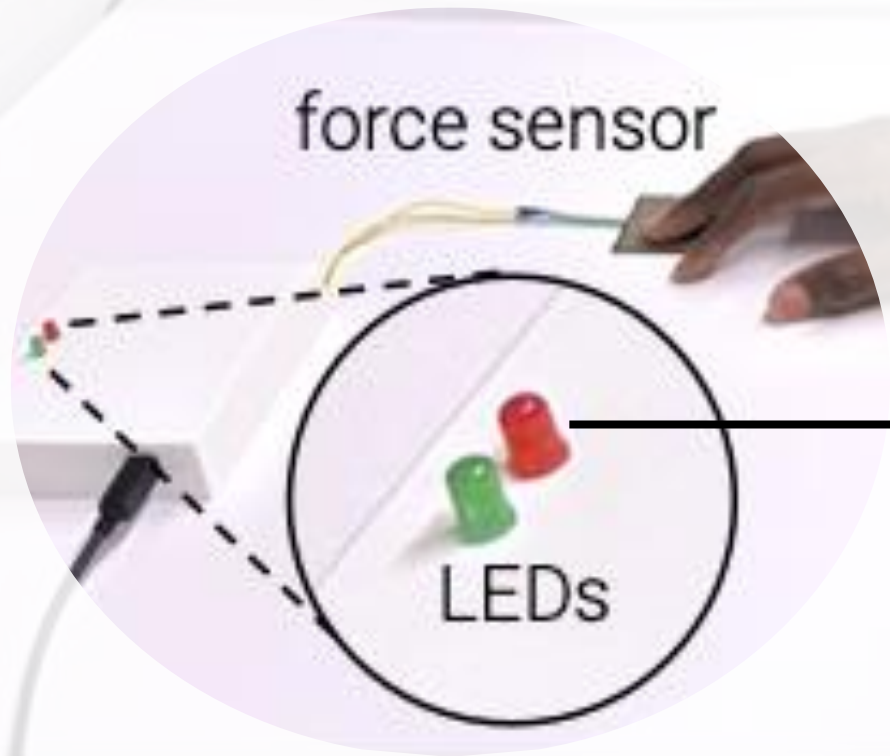

result from user study (N=12, 1080 trials):
improved reaction-time by ~25 ms

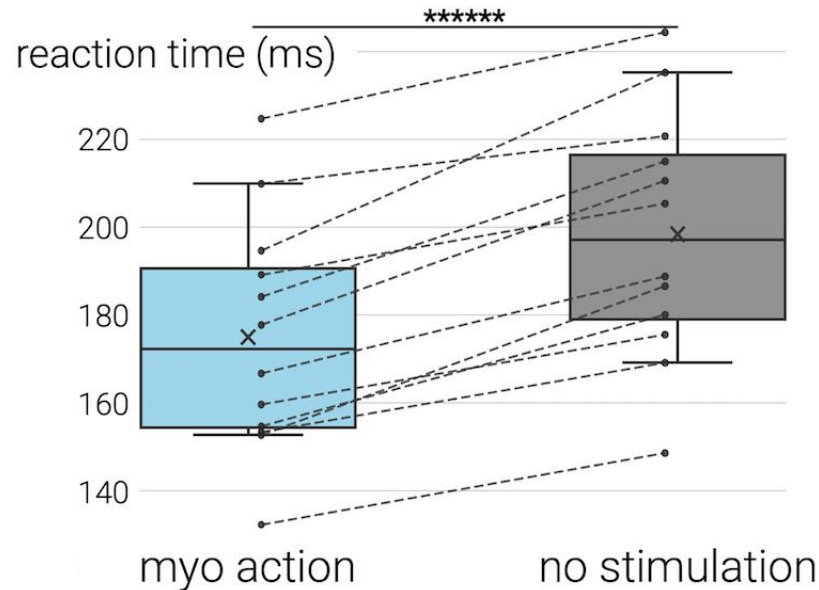

result from user study (N=12, 1080 trials):
intention classification accuracy

F1 score: **~0.95**

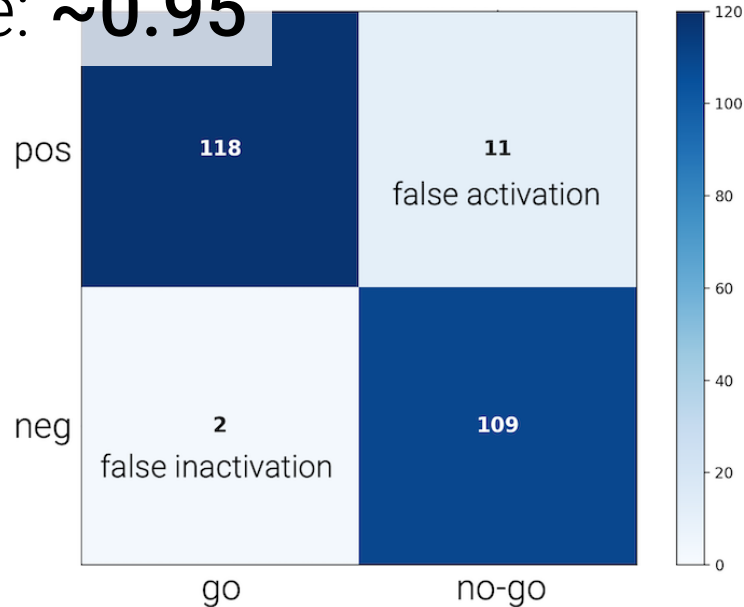

result from user study (N=12, 1080 trials):
perceived agency in decision-based actions

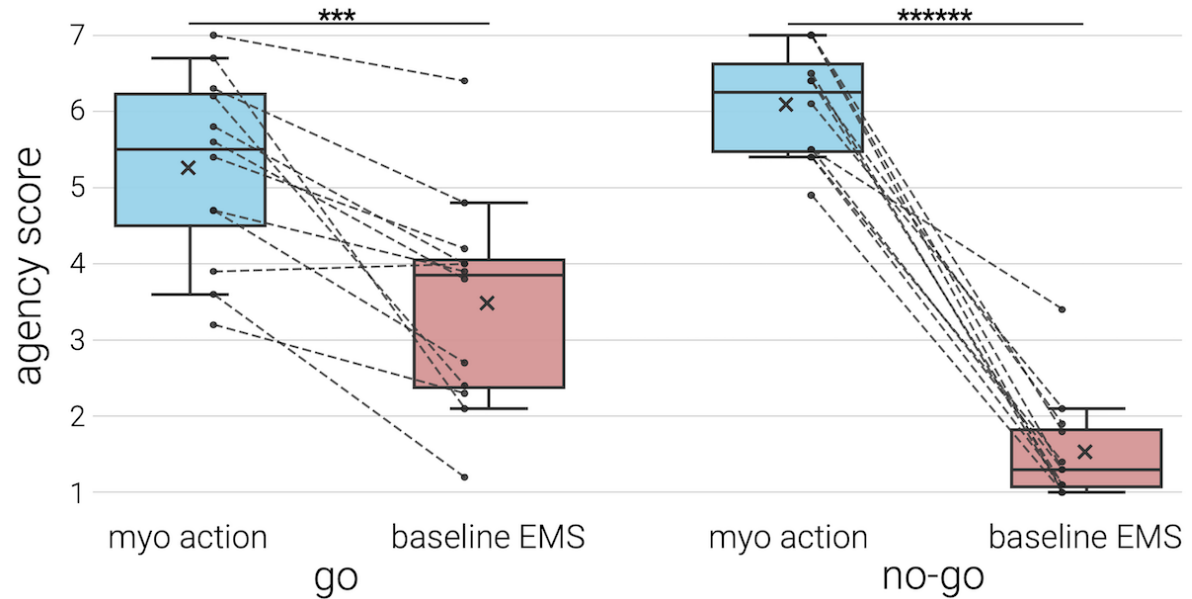

conclusions and takeaways



conceptual diagram

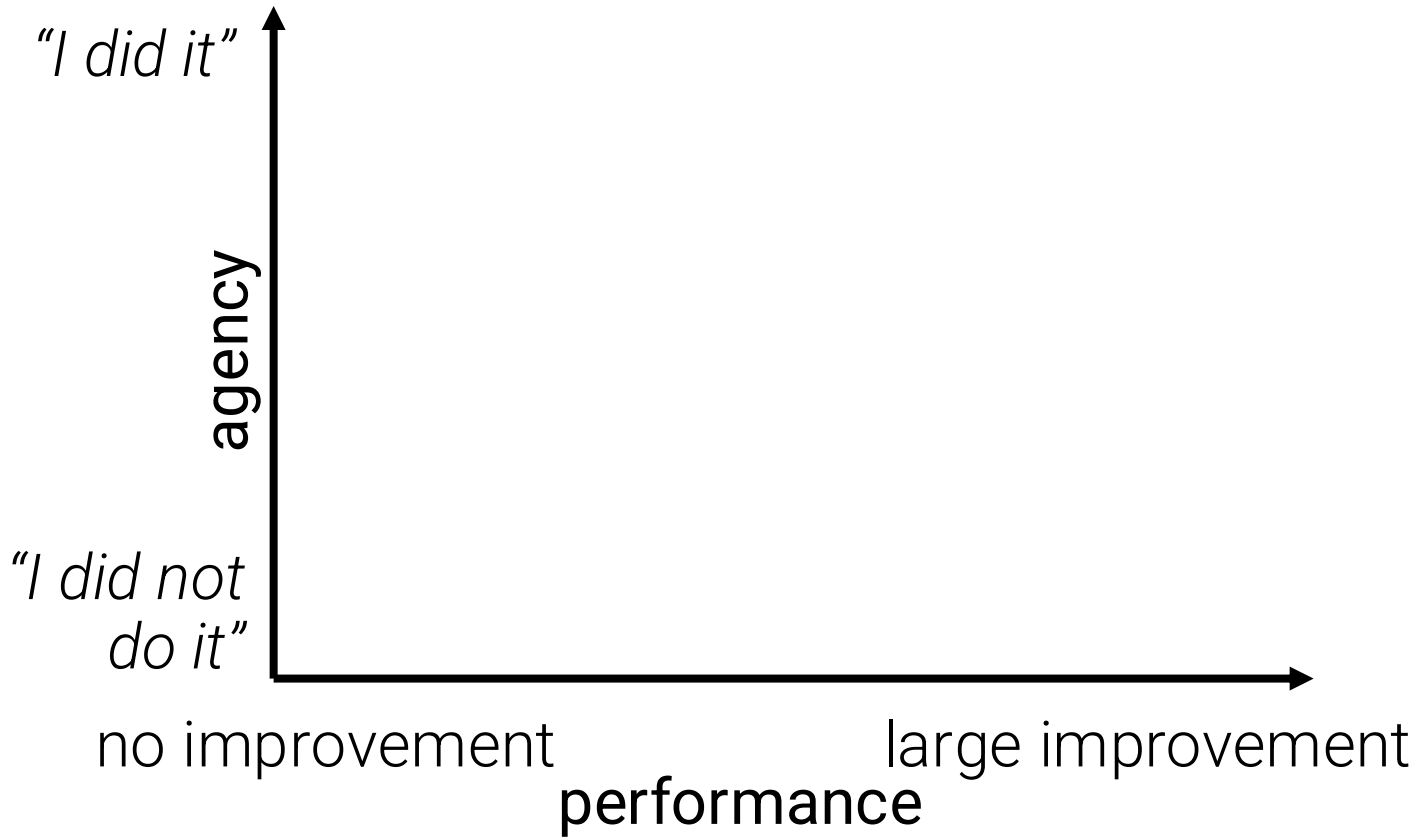

conceptual diagram

— traditional assistive devices

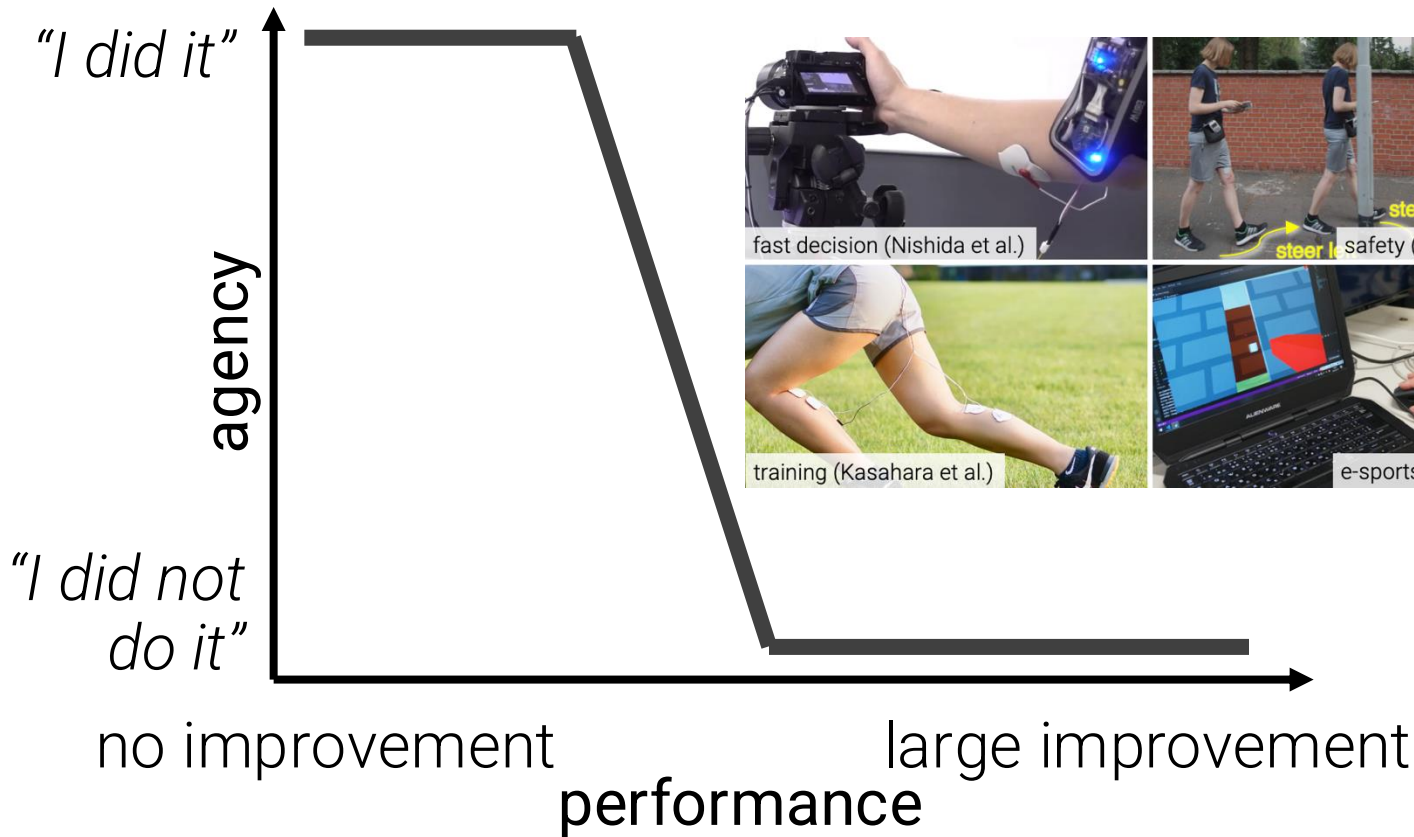

conceptual diagram

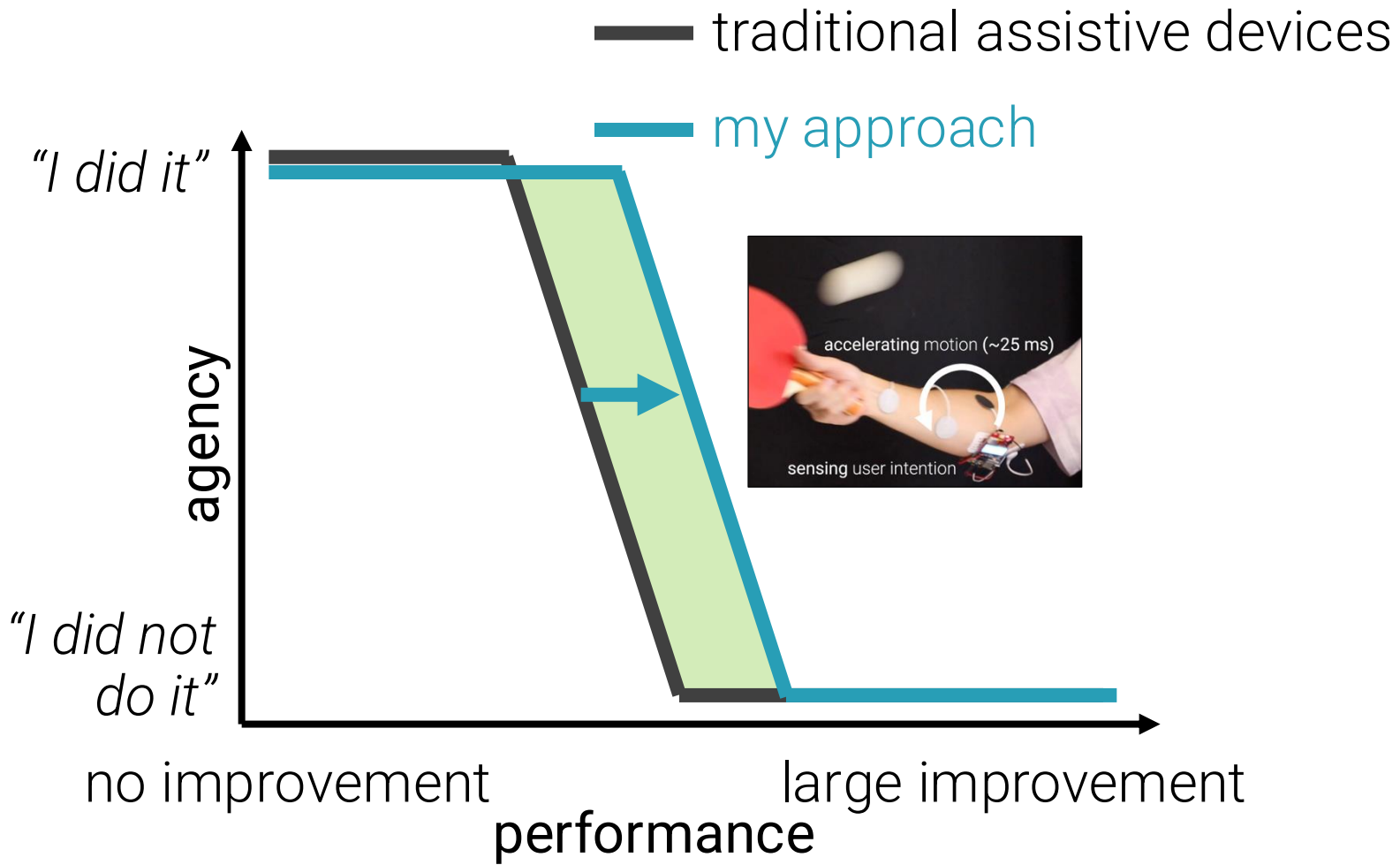

conceptual diagram

— traditional assistive devices

— my approach

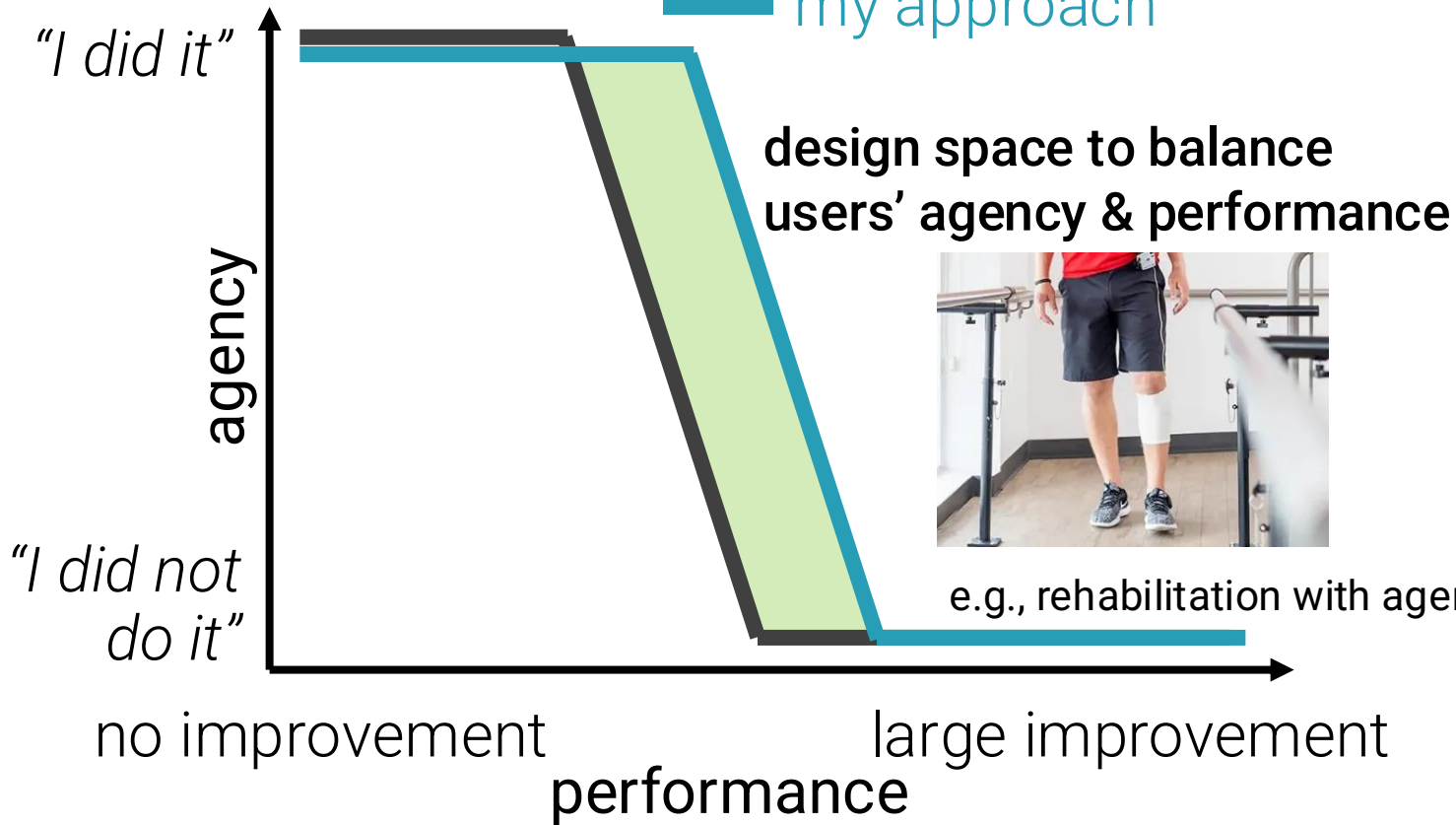

conceptual diagram

physiological alignment

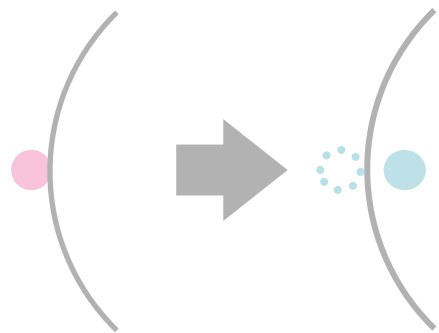

CHI '23 **best paper**

psychological alignment

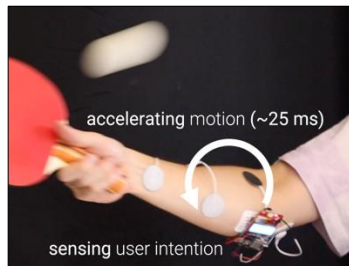
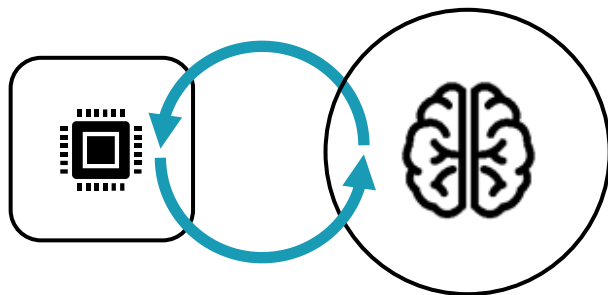

CHI '26

toward general-purpose

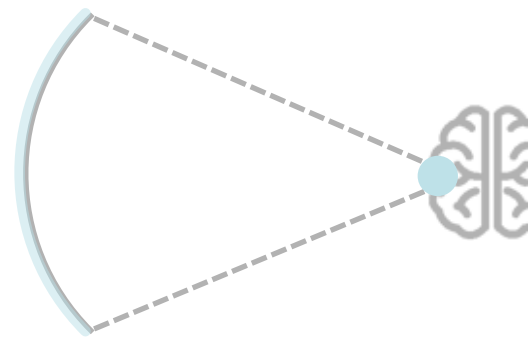

CHI '24 **honorable mention**

installing abilities into users' nervous systems

physiological alignment

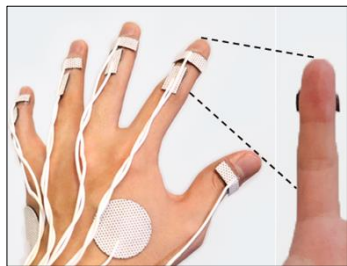
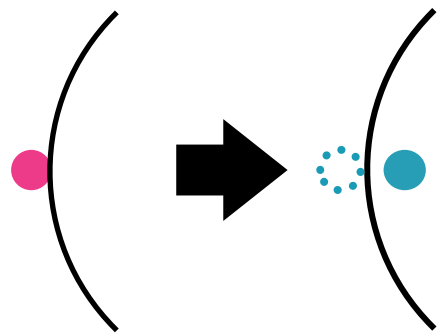

CHI '23 **best paper**

psychological alignment

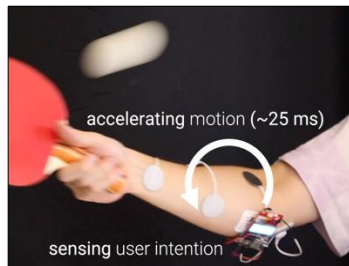
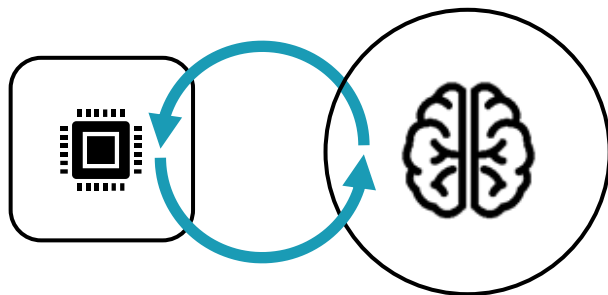

CHI '26

toward **general-purpose**

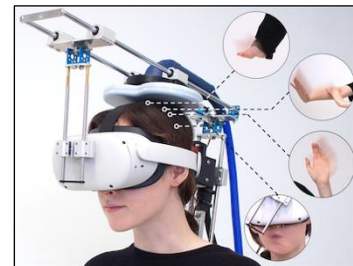
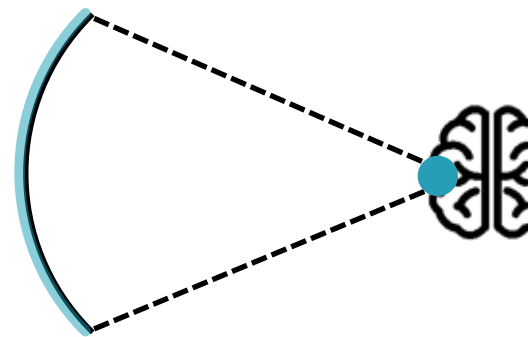

CHI '24 **honorable mention**

starting my lab in U.S. (details coming soon)!



installing abilities into users' nervous systems

physiological alignment

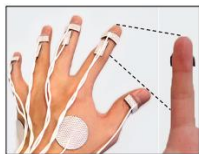
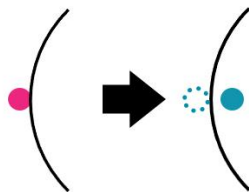

CHI '23 **best paper**

psychological alignment

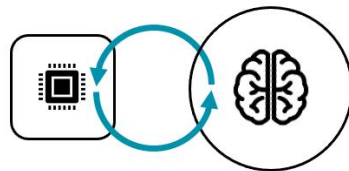

CHI '26

toward **general-purpose**

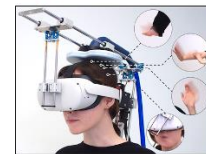
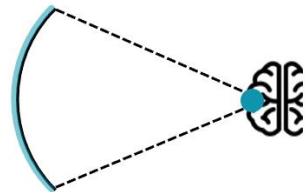

CHI '24 **honorable mention**

yudai tanaka | yudai-tanaka.com | yudaitanaka@uchicago.edu



README // about these slides

These are the slides for the talk presented at CHI 2026 by Yudai Tanaka.

All the links in this PDF are clickable and lead you to YouTube videos, paper, etc.

You can watch the live talk [here: https://youtu.be/nQI-65DbsIA?si=y7G4ILrXUZf0upAp](https://youtu.be/nQI-65DbsIA?si=y7G4ILrXUZf0upAp)

You can watch the video [here: https://www.youtube.com/watch?v=M0EVjipRmPU](https://www.youtube.com/watch?v=M0EVjipRmPU)

If you need a PPTX/editable version for your class, email us hci@uchicago.edu

More on this paper (or others of our lab) at: <https://lab.plopes.org/#myoaction>

Myo Action: Accelerating Voluntary Actions via Electromyography and Muscle Stimulation

Yudai Tanaka, Che-Wei Hsu, Bruno Felalaga, Pedro Lopes. In Proc. CHI'26 (paper)

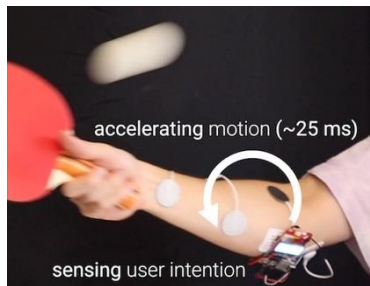

We propose a technique for accelerating users' action without overriding intention, thereby preserving agency. In our approach, it is the user's muscle signals, detected via electromyography (EMG), that trigger electrical-muscle-stimulation (EMS) without external sensors or stimulation-timing calibration. The key to enable this "agentic speedup" is a synergy between EMG and EMS: EMG can detect an early-onset of the neural-response; EMS can contract a muscle faster than a typical voluntary-contraction. This—coupled with our low-latency system (290 μ s)—results in an accelerated reaction time, even though the haptic-assistance is initiated after the muscle-signal. In our study, we confirmed that our novel approach: accelerated users' reaction-time; preserved agency in decision-involving actions (i.e., go/no-go trials); and participants felt it augmented their performance. This puts forward embodied-assistance that aligns with users' decisions/intentions.



[click for paper PDF](#)



[click for Paper Video](#)



[click for CHI Talk \(live\)](#)